



YING SHUN MACHINERY INDUSTRY CO., LTD.

Vertical Turret Milling Machine

YSM-15 SERIES



MECHANICAL FEATURE

- The main casting part is made of meehanite casting.
- Milling head type:
Variable (V) Steps (S) Inverter (C)
- The spindle is one piece machined from SCM440 alloysteel, high-frequency and precision polishing.
- Used type B belt drive.
- Turcite-B coated on X Y ways.



MECHANICAL DIMENSIONS

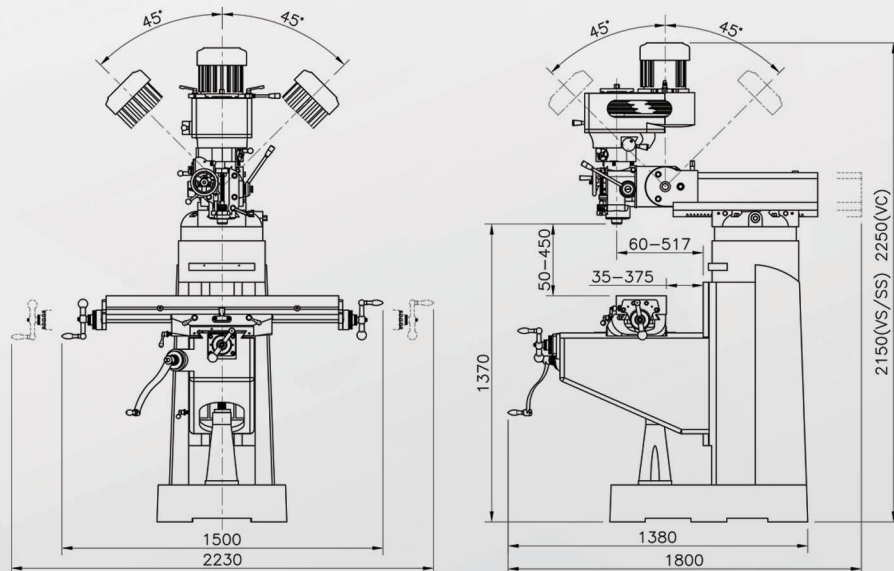

SPECIFICATIONS AND ACCESSORIES

Model	Unit	15VS	15SS	15VC
Travel				
Longitudinal travel (M./A.)	mm	700/650(Opt.875/825)		
Cross travel (M./A.)	mm	360		
Vertical travel (M./A.)	mm	400		
Slideway X/Y/Z	type	△ / △ / △		
Quill travel	mm	127		
Overarm travel	mm	457		
Overarm swivel	degree	360		
Quill swivel (R&L)/(F&B)	degree	±45/±45		
Table				
Dimension	mm	1067x230(Opt.1244x230)		
T-slots (WidthxNo.xPitch)	mm	16x3x63		
Spindle				
Milling head	type	Variable	8/16 Steps	Inverter
Speed	60Hz	rpm	66-2700(8)	55-3600
	50Hz	rpm	50-3500	
		rpm	68-4560(16)	
Vertical feeds	mm/rev	0.04/0.08/0.15		
Taper	type	NT 30 or R8 (Opt.NT40)		
Quill Diameter	mm	85		
Motor				
Main spindle	HP	3	3	5
Machine				
Net Weight	kg	900		

Standard accessories

- Draw bar
- Tool box and tools
- Chip cover on Y axis
- Manual lubrication system

Optional accessories

- Draw bar(pneumatic)
- Working lamp
- Auto lubrication system
- Power feed(X/Y/Z)
- Gear box(X/Y)
- Servo feed(X/Y)
- Z axis rapid up/down
- Electric box (simple/general /deluxe)
- Ball screw (X/Y)
- 4"/6"/8"(100/150/200mm)riser block
- Digital readout (DRO)
- Coolant system(Pump 1/8HP)
- Chip tray



YING SHUN MACHINERY INDUSTRY CO., LTD.

All specification , dimension and design characteristics shown in this catalogue are subject to change without notice.

No.5,Aly.162,Ln.136,Sec.1,Jiahou Rd.,Houli Dist., Taichung City 421,Taiwan(R.O.C.)

TEL:+886-4-25586346

ys@yingshun.com.tw

FAX:+886-4-25586930

<https://www.yingshun.com.tw>