

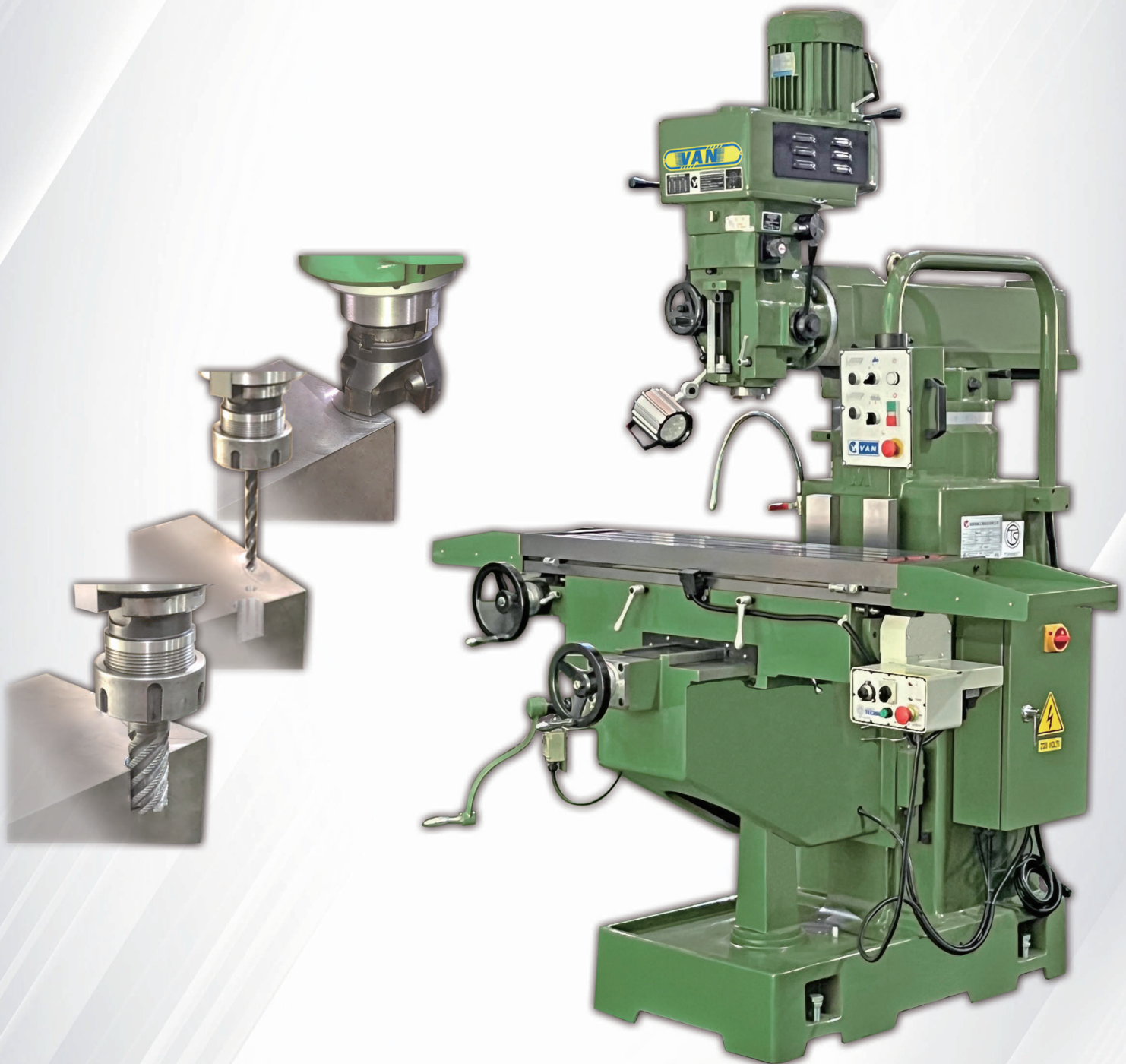

YING SHUN
MACHINERY INDUSTRY CO., LTD.

Vertical Turret Milling Machine

YSM-860 SERIES



MECHANICAL FEATURE

- The main casting part is made of meehanite casting.
- Milling head type:
 - Steps (S) Inverter (C)
- The spindle is one piece machined from SCM440 alloy steel, high-frequency and precision polishing.
- X/Y axis are using precision ball screw.



MECHANICAL DIMENSIONS

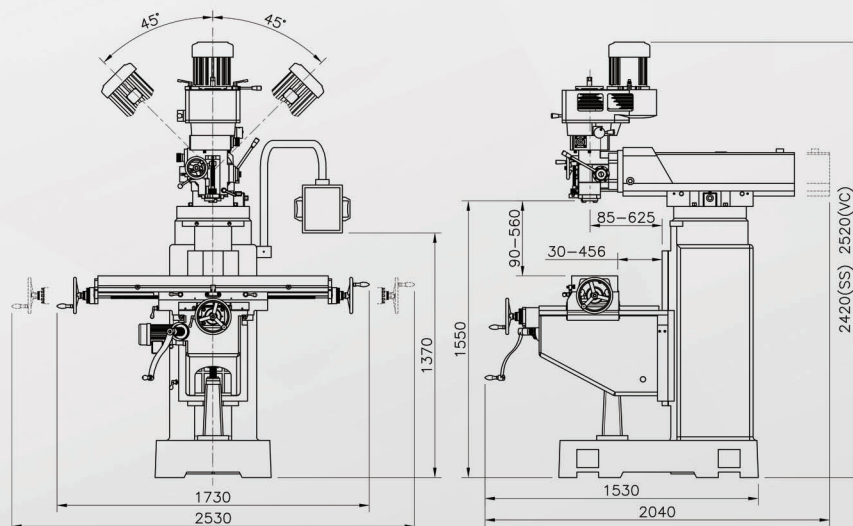

SPECIFICATIONS AND ACCESSORIES

Model	Unit	860S	860C
Travel			
Longitudinal travel (M./A.)	mm	860(Opt.1000)	
Cross travel (M./A.)	mm	400	
Vertical travel (M./A.)	mm	470	
Slideway X/Y/Z	type	△ / □ / □	
Quill travel	mm	140	
Overarm travel	mm	540	
Overarm swivel	degree	360	
Quill swivel (R&L)/(F&B)	degree	±45/Fixed(Opt.±45)	
Table			
Dimension	mm	1270x300(Opt.1370x300)	
T-slots (WidthxNo.xPitch)	mm	16x3x70	
Spindle			
Milling head	type	10/20 Steps	Inverter
Speed	60Hz	rpm	70-3350(10)
	50Hz	rpm	58-2780(10)
		rpm	58-5560(20)
Vertical feeds	mm/rev	0.04/0.08/0.15	
Taper	type	NT40	
Quill Diameter	mm	105	
Motor			
Main spindle	HP	5	
X-axis traverse	HP	1/2	
Z axis elevation	HP	1/2	
feedrate			
X-axis speed	mm/min	0-1500	
Z axis speed	mm/min	345	
Machine			
Net Weight	kg	1700	

Standard accessories

- Draw bar
- Tool box and tools
- Chip cover on Y axis
- Auto lubrication system
- Working lamp
- Z Axis Rapid up/down
- Deluxe type operation panel
- X axis servo feed
- Electric box
- X/Y axis Ball screw

Optional accessories

- Power drawbar
- Power feed(X/Y)
- Servo feed(Y)
- Gear box(X/Y)
- 100/150/200mm riser block
- Digital readout (DRO)
- Coolant system(Pump 1/8HP)
- Chip tray



YING SHUN MACHINERY INDUSTRY CO., LTD.

All specification, dimension and design characteristics shown in this catalogue are subject to change without notice.

No.5,Aly.162,Ln.136,Sec.1,Jiahou Rd.,Houli Dist., Taichung City 421,Taiwan(R.O.C.)

TEL:+886-4-25586346

FAX:+886-4-25586930

ys@yingshun.com.tw

https://www.yingshun.com.tw